

**Specified Technologies, Inc.**  
**Design No. STI/PF 60-04**



Through Penetration  
 SpecSeal® LCI Intumescent Firestop Sealant  
 ASTM E814, CAN/ULC-S115  
 Rating: See Table 1

Pressure Differential: Positive, 0.01 in. w.g. (2.5 Pa)

TABLE 1. RATINGS		
	ASTM E814	CAN/ULC-S115
F-Rating	1 Hr	1 Hr
T-Rating	0 Hr	NA
FT-Rating	NA	0 Hr
FH-Rating	NA	1 Hr
FTH Rating	NA	0 Hr

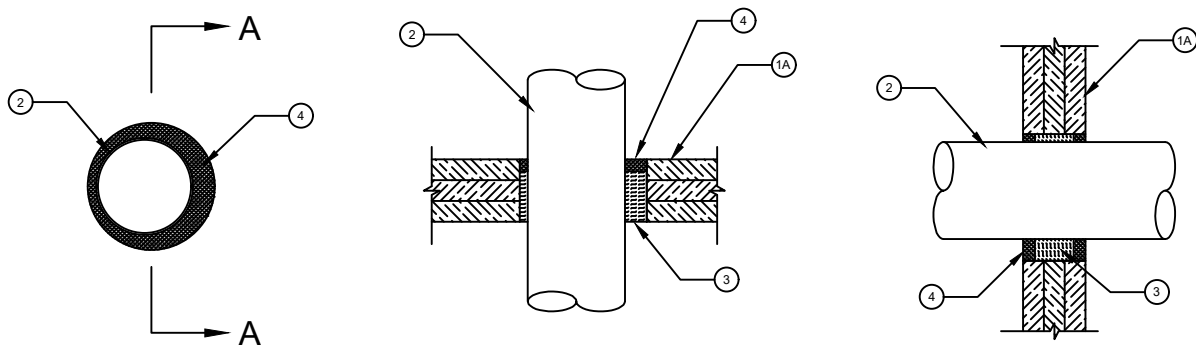

Section A-A

Figure 1. Through Penetration Detail

1. **SUPPORTING CONSTRUCTION:** Use Cross-laminated timber (CLT) certified in accordance with ANSI/APA PRG 320 (2018 or later). Use a min. 1 hour fire-rated floor/ceiling assembly or wall assembly constructed in accordance with its listed or prescribed fire-rated design requirements that has a maximum through opening diameter of 8 in. (203-mm) and meets the following minimum construction requirements:
  - A. Cross Laminated Timber (CLT): Use min. 3- 15/16 in. (100mm) thick CLT with a min. of 3 plies. Minimum ply thickness is 1-3/16 in. (30 mm).
  - B. Gypsum Board: (Optional, not shown) Gypsum board of any thickness or type may be applied directly to the underside of CLT floor/ceiling assemblies or on both sides of CLT wall assemblies. Secure as recommended by the gypsum manufacturer instructions or as needed to comply with local code requirements.
  - C. Floor Topping (For floor configuration only, Optional, Not Shown) - Use a code compliant floor topping when acceptable for use in the listed or prescribed fire rated floor/ceiling design.



**2. PENETRATING ITEM:** Install penetrating items centered or offset within the opening. The annular space and offset shall range from min. 1/2 in. (13 mm) to max. 1-3/8 in. (35 mm) within the opening. Use one of the following penetrating items:

- Max 6 in. (152 mm) diameter Schedule 10 (or thicker) steel pipe.
- Max 6 in. (152 mm) diameter cast or ductile iron pipe.
- Max 6 in. (152 mm) diameter copper pipe or Tube (Type L or heavier).
- Max 6 in. (152mm) diameter steel RMC conduit.
- Max 4 in. (102 mm) diameter steel EMT or IMC conduit.

**3. PACKING MATERIAL:** Use only packing material bearing an Intertek Certified Label and meeting the following min. requirements. Install min. 4-pcf (64-kg/m<sup>3</sup>) mineral wool insulation in the annular space of the opening in the floor/ceiling assembly or wall assembly (Item 1) to the full depth of the supporting construction except recessed nominal 3/4 in. (19mm) from the top of the CLT floor/ceiling assembly or both sides of the CLT wall assembly. Tightly pack the insulation (compress minimum 50%) around the penetrating item (Item 2).

**4. FILL, VOID, OR CAVITY MATERIAL:** Apply the following material in accordance with manufacturer's instructions and in compliance with the requirements below:

Certified Product: Specified Technologies, Inc. SpecSeal® LCI Intumescent Firestop Sealant

Apply nominal 3/4 in. (19 mm) depth of SpecSeal® LCI Intumescent Firestop Sealant over the packing material (Item 3) to fill the annular space so that it is flush with the top side of the CLT floor/ceiling assembly, or with both sides of the CLT wall assembly.

Consult the listing report on the Directory of Building Products (<https://bpdirectory.intertek.com>) for the edition of the standard(s) evaluated.

Compliance of the assembly described in this Design Listing with the referenced standard relies on verification that the assembly constructed in the field is consistent with that described herein. Intertek certified products may be verified by the approved Intertek label; other products must be verified by the Authority Having Jurisdiction as meeting the specifications stated herein.

