

System No. HW-D-0689

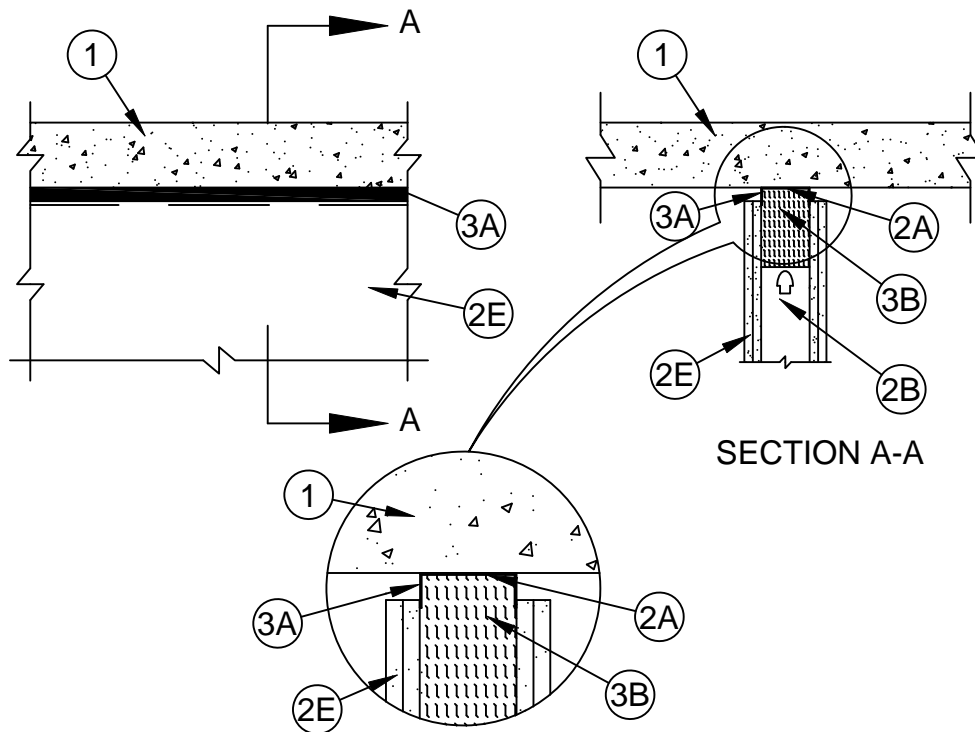

ANSI/UL2079	CAN/ULC S115
Assembly Ratings - 1 and 2 Hr (See Item 2)	F Ratings - 1 and 2 Hr (See Item 2)
Nominal Joint Width - 1/2 in.	FT Ratings - 1 and 2 Hr (See Item 2)
Class II or III Movement Capabilities - 100% Compression or Extension (See Item 3)	FH Ratings - 1 and 2 Hr (See Item 2)
L Rating at Ambient - Less Than 1 CFM/Lin Ft	FTH Ratings - 1 and 2 Hr (See Item 2)
L Rating at 400°F - Less Than 1 CFM/Lin Ft	Nominal Joint Width - 13 mm
	Class II or III Movement Capabilities - 100% Compression or Extension (See Item 3)
	L Rating at Ambient - Less Than 1.55 L/s/m
	L Rating at 204°C - Less Than 1.55 L/s/m



1. **Floor Assembly** - Min 4-1/2 in. (114 mm) thick steel-reinforced lightweight or normal weight (100-150 pcf or 1600-2400 kg/m³) structural concrete. Floor may also be constructed of any min 6 in. thick (152 mm) UL Classified hollow-core Precast Concrete Units*.

See **Precast Concrete Units** (CFTV) category in Fire Resistance Directory for names of manufacturers.

2. **Wall Assembly** - The 1 or 2 hr fire-rated gypsum board/stud wall assembly shall be constructed of the materials and in the manner described in the individual U400, V400 or W400 Series Wall and Partition Design in the UL Fire Resistance Directory and shall include the following construction features:

A. **Steel Floor and Ceiling Runners** - Floor and ceiling runners of wall assembly shall consist of galv steel channels sized to accommodate steel studs (Item 2B). Length of flange to equal fully extended width of joint plus 1/4 in. (6 mm).. Ceiling runner secured to concrete floor slab with steel masonry anchors spaced max 24 in. (610 mm) OC or min 1 in. (25 mm) long steel masonry or powder actuated fasteners spaced at a max of 24 in. (610 mm) OC.



Specified Technologies Inc. 210 Evans Way Somerville, NJ 08876

Reproduced courtesy of Underwriters Laboratories, Inc.

Created or Revised: February 27, 2018

(800)992-1180 • (908)526-8000 • FAX (908)231-8415 • E-Mail:techserv@stifirestop.com • Website:www.stifirestop.com



HW-D-0689
PAGE 1 OF 3

- A1. **Light Gauge Framing* - Vertical Deflection Ceiling Runner** - As an alternate to the ceiling runner in Item 2A, vertical deflection ceiling runner to consist of galv steel channel with slotted vertical deflection clips mechanically fastened within runner. Slotted clip provided with step bushings for permanent fastening of steel studs. Flanges sized to accommodate steel studs (Item 2B). Vertical deflection ceiling runner secured to concrete floor slab with steel masonry anchors spaced max 24 in. (610 mm) OC.

THE STEEL NETWORK INC - VertiTrack VTD358, VTD400, VTD600 and VTD800

- A2. **Light Gauge Framing* - Notched Ceiling Runner** - As an alternate to the ceiling runners in Items 2A or 2A1, notched ceiling runners to consist of C-shaped galv steel channel with notched return flanges sized to accommodate steel studs (Item 2B). Notched ceiling runner secured to concrete floor slab with steel masonry anchors spaced max 24 in. (610 mm) OC.

OLMAR SUPPLY INC - Type SCR

- A3. **Light Gauge Framing* - Slotted Ceiling Runner** - As an alternate to the ceiling runner in Item 2A through 2A2, ceiling runner to consist of galv steel channel with slotted flanges sized to accommodate steel studs (Items 2B). Ceiling runner secured to concrete floor slab with steel masonry anchors spaced max 24 in. (610 mm) OC. See Item 2C for more information.

BRADY CONSTRUCTION INNOVATIONS INC, DBA SLIPTRACK SYSTEMS - SLP-TRK

CALIFORNIA EXPANDED METAL PRODUCTS CO - CST

CLARKDIETRICH BUILDING SYSTEMS - Type SLT, SLT-H

METAL-LITE INC - The System

RAM SALES L L C - RAM Slotted Track

SCAFCO STEEL STUD MANUFACTURING CO - Slotted Track

MARINO/WARE, DIV OF WARE INDUSTRIES INC - Type SLT slotted track

- B. **Studs** - Steel studs to be min 3-1/2 in. (89 mm) wide. Studs cut 1/2 in. (13 mm) less in length than assembly height with bottom nesting in and resting on floor runner and with top nesting in ceiling runner without attachment. When vertical deflection ceiling runner (Item 2A1) is used, steel studs secured to slotted vertical deflection clips, through bushings, with steel screws at mid-height of each slot. When slotted ceiling runner (Item 2A3) is used, steel studs secured to slotted ceiling runner with No. 8 by 1/2 in. (13 mm) long wafer head steel screws at mid-height of slot on each side of wall. Stud spacing not to exceed 24 in. (610 mm) OC.
- C. **Batts and Blankets*** - (Not Shown) - As an alternate to the forming material (Item 3B), min 2.5 pcf (40 kg/m³) mineral wool batt insulation, of a width and thickness to completely fill stud cavity. Insulation batts friction fit to completely fill all stud cavities below the bottom surface of the steel ceiling runner.
- See **Batts and Blankets** (BZJZ) category in the Fire Resistance Directory for names of manufacturers.
- D. **Batts and Blankets*** - (Not Shown) - In 1 hr fire rated wall assemblies as an alternate to the forming material (Item 3B), any glass fiber insulation bearing the UL Classification Marking as to fire resistance or surface burning characteristics, of a width and thickness to completely fill stud cavity. Insulation batts friction fit to completely fill all stud cavities below the bottom surface of the steel ceiling runner. At the steel ceiling runner, the top 6 in. (152 mm) section of insulation to be folded back upon itself to double the density at this location.
- See **Batts and Blankets** (BZJZ) category in the Fire Resistance Directory for names of manufacturers.
- E. **Gypsum Board*** - Gypsum board sheets installed to a min total thickness of 5/8 in. (16 mm) and 1-1/4 in. (32 mm) on each side of wall for 1 and 2 hr fire rated assemblies, respectively. Wall to be constructed as specified in the individual Wall and Partition Design in the UL Fire Resistance Directory, except that a nom 1/2 in. (13 mm) gap shall be maintained between the top of the gypsum board and the bottom surface of the floor. In addition, the top row of screws shall be installed into the steel studs 1/2 to 5 in. (13 to 127 mm) below the bottom edge of the ceiling runner flange.

The hourly fire rating of the joint system is dependent on the hourly fire rating of the wall assembly in which it is installed.



Specified Technologies Inc. 210 Evans Way Somerville, NJ 08876

Reproduced courtesy of Underwriters Laboratories, Inc.
Created or Revised: February 27, 2018

(800)992-1180 • (908)526-8000 • FAX (908)231-8415 • E-Mail:techserv@stifirestop.com • Website:www.stifirestop.com



HW-D-0689
PAGE 2 OF 3

3. **Joint System - Max separation between bottom of floor and top of wall is 1/2 in. (13 mm). The joint system is designed to accommodate a max 100 percent compression or extension from its installed width.** The joint system consists of the following:

A. **Fill, Void or Cavity Material*** - Factory-supplied intumescent gasket installed and nominally centered over the ceiling runner (Item 2A through 2A3) prior to attachment to underside of concrete floor. Gypsum board layers to be installed on both sides of the wall maintaining a minimum 5/8 in. (16 mm) overlap over the intumescent gasket at time of installation.

SPECIFIED TECHNOLOGIES INC - Speed Flex Track Top Gasket

B. **Forming Material*** - When stud cavities are not filled with mineral wool batt insulation or glass fiber insulation (Items 2C or 2D), nom 4 in. (102 mm) thick by 6 in. (152 mm) wide sections of 4 pcf (64 kg/m³) mineral wool batt insulation installed between studs (Item 2B) flush with the bottom surface of the steel ceiling runner.

INDUSTRIAL INSULATION GROUP L L C - MinWool-1200 Safing

JOHNS MANVILLE - Safing

ROCK WOOL MANUFACTURING CO - Delta Board

ROCKWOOL MALAYSIA SDN BHD - Safe

ROCKWOOL - Safe

THERMAFIBER INC - SAF

* Indicates such products shall bear the UL or cUL Certification Mark for jurisdictions employing the UL or cUL Certification (such as Canada), respectively.



Specified Technologies Inc. 210 Evans Way Somerville, NJ 08876

Reproduced courtesy of Underwriters Laboratories, Inc.

Created or Revised: February 27, 2018

(800)992-1180 • (908)526-8000 • FAX (908)231-8415 • E-Mail:techserv@stifirestop.com • Website:www.stifirestop.com



HW-D-0689
PAGE 3 OF 3