

System No. F-B-2066

F Rating - 2 Hr
T Rating - 3/4 Hr
L Rating At Ambient - Less Than 1 CFM/ft²
L Rating At 400 F - Less Than 1 CFM/ft²

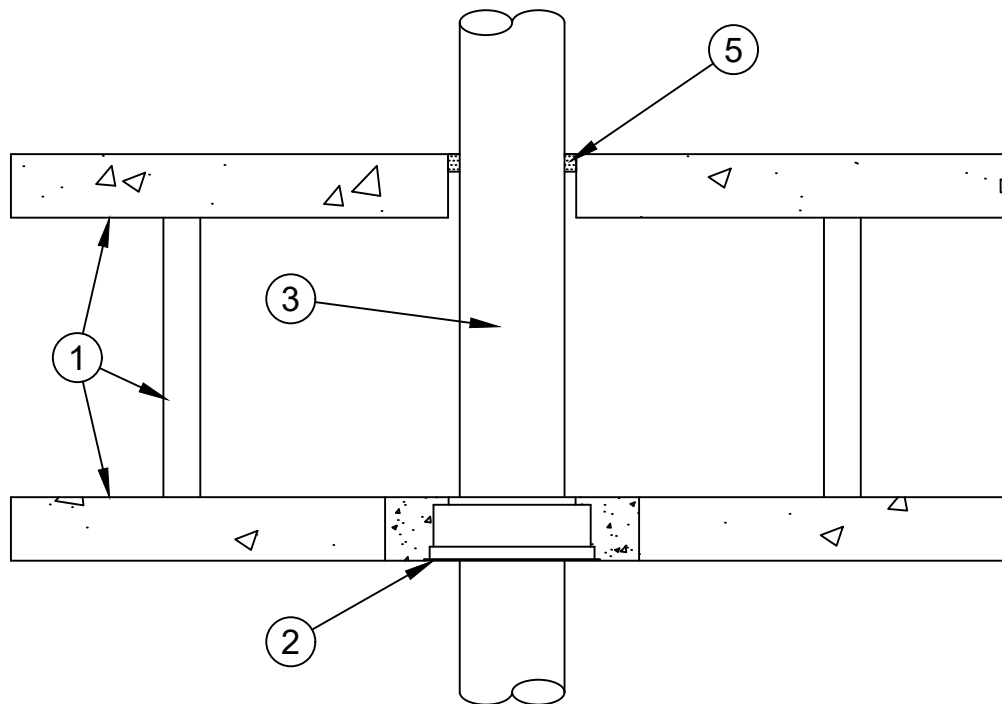

1. **Precast Concrete Units (CFTV)*** - Precast, pre-stressed, dual deck units constructed in accordance with Floor-Ceiling Design No. K919. At top of floor, diam of opening to be max 1 in. (25 mm) greater than the diam of the penetrant.

FINROCK INDUSTRIES INC - Type Dual Deck

2. **Firestop Device*** - Cast in place firestop device permanently embedded during the concrete pour or grouted into the concrete assembly in accordance with the accompanying installation instructions. The throat of the firestop device may be cut flush with the top surface of the floor or extend beyond the top surface of the floor.

SPECIFIED TECHNOLOGIES INC - SpecSeal CD200, CD201, CD201C, CD202, CD300, CD301, CD301C, CD302, CD400, CD401 or CD402 Cast In Firestop Device. When SpecSeal CD200, CD300, CD400 is used, device fitted with steel top ring.

3. **Through Penetrant** - One nonmetallic pipe or conduit to be centered within the firestop device. At top of floor, the annular space between the pipe or conduit and the periphery of the opening shall be min 0 in. (point contact) to max 1 in. (25 mm). Pipe or conduit to be rigidly supported on both sides of the floor assembly. The following types and sizes of nonmetallic pipes or conduits may be used:

- A. **Polyvinyl Chloride (PVC) Pipe** - Nom 4 in. (102 mm) diam (or smaller) solid or cellular core Schedule 40 polyvinyl chloride (PVC) pipe for use in closed (process or supply) or vented (drain, waste or vent) piping systems.
- B. **Chlorinated Polyvinyl Chloride (CPVC) Pipe** - Nom 4 in. (102 mm) diam (or smaller) SDR 13.5 chlorinated polyvinyl chloride (CPVC) pipe for use in closed (process or supply) piping systems.
- C. **Rigid Nonmetallic Conduit+** - Nom 4 in. (102 mm) diam (or smaller) Schedule 40 PVC conduit installed in accordance with the National Electrical Code (NFPA 70).



Specified Technologies Inc. 210 Evans Way Somerville, NJ 08876

Reproduced courtesy of Underwriters Laboratories, Inc.

Created or Revised: December 09, 2018

(800)992-1180 • (908)526-8000 • FAX (908)231-8415 • E-Mail:techserv@stifirestop.com • Website:www.stifirestop.com



F-B-2066
PAGE 1 OF 2

Nom Pipe Diam (a)	Firestop Device
1-1/2 or 2 in. (38 or 51 mm)	CD200, CD201, CD201C, CD202
2-1/2 or 3 in. (64 or 76 mm)	CD300, CD301, CD301C, CD302
3-1/2 or 4 in. (89 or 102 mm)	CD400, CD401, CD402

(a) When nonmetallic pipe or conduit with diam smaller than those shown in the table above is used, packing material shall be installed into the device as described in Item 4.

4. **Packing Material** - (Not Shown) - When required under Item 3, min 2 in. (51 mm) thickness of min 4 pcf (64 kg/m³) mineral wool firmly packed into device flush with top edge of device (Item 2), and extending a min 1 in. (25 mm) below the top surface of the floor.
5. **Fill, Void or Cavity Material* - Sealant** - At top of floor, min 3/4 in. (19 mm) thickness of fill material applied within the annulus, flush with the top surface of the floor. At point contact location between penetrating item and concrete, a min 1/4 in. (6 mm) diam bead of fill material shall be applied at the concrete/penetrating item interface on the top surface of the floor.

SPECIFIED TECHNOLOGIES INC - SpecSeal Series SSS Sealant, SpecSeal LCI Sealant or SpecSeal SIL300 Sealant

* Indicates such products shall bear the UL or cUL Certification Mark for jurisdictions employing the UL or cUL Certification (such as Canada), respectively.



Specified Technologies Inc. 210 Evans Way Somerville, NJ 08876

Reproduced courtesy of Underwriters Laboratories, Inc.

Created or Revised: December 09, 2018

(800)992-1180 • (908)526-8000 • FAX (908)231-8415 • E-Mail:techserv@stifirestop.com • Website:www.stifirestop.com



F-B-2066

PAGE 2 OF 2