

System No. CW-S-0002

F Rating - 2 Hr

T Rating - 1/2 Hr

Linear Opening Width - 2 In. Max

L Rating At Ambient - Less Than 1 CFM/Lin Ft

L Rating At 400°F - Less Than 1 CFM/Lin Ft

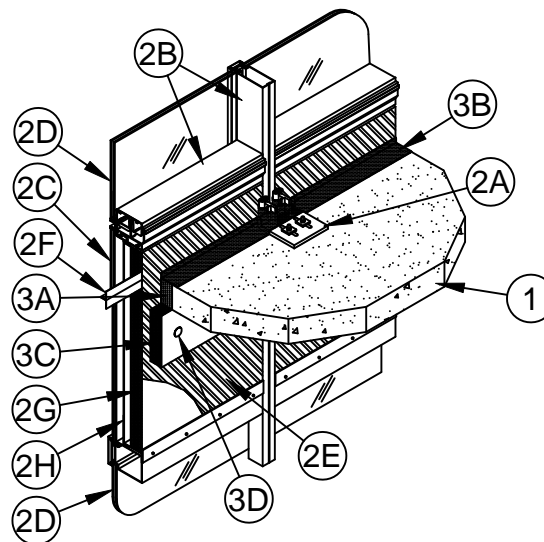

1. **Floor Assembly** - Min 4-1/2 in. (114 mm) thick reinforced lightweight or normal weight (100-150 pcf or 1600-2400 kg/m³) structural concrete.
2. **Curtain Wall Assembly** - The factory-assembled curtain wall assembly shall incorporate the following construction features:
 - A. **Mullion Mounting Brackets** - Min 8 in. (203 mm) wide by 3/4 in. (19 mm) thick extruded aluminum Halfen mounting brackets with one nom 2 in. (51 mm) high leg for support and attachment of mullion and with one leg at least 6 in. (152 mm) longer than the width of linear opening between floor assembly and mullion. Mounting bracket attached to top of floor with two min 1/2 in. (13 mm) diam steel masonry anchors in conjunction with washer plates supplied with mounting bracket.
 - B. **Framing** - The one or two-piece rectangular tubing mullions (vertical members) and transoms (horizontal members) shall be min 2-1/2 in. (64 mm) wide by 5 in. (127 mm) deep and shall be formed from min 0.100 in. (2.5 mm) thick aluminum. Mullions spaced max 60 in. (1.52 m) OC and secured to mullion mounting anchors (Item 2A) at each floor level in conjunction with extruded aluminum clips bolted to the sides of the mullions and designed to engage the vertical leg of the Halfen mullion mounting bracket in conjunction with an extruded aluminum hook/leveling connector. Interior face of mullions to be max 2 in. (51 mm) from edge of floor assembly. Transoms to be spaced min 36 in. (0.91 m) OC. Sill of vision panel to be located min 6 in. (152 mm) above top surface of floor assembly.
 - C. **Spandrel Panels** - The spandrel panels shall consist of one of the following types:
 - a. **Glass Panels** - Min 1/4 in. (6 mm) thick transparent or opaque heat-strengthened glass or min 1 in. (25 mm) thick insulated glass units with two layers of nom 1/4 in. (6 mm) thick heat-strengthened glass separated by a min 1/2 in. (25 mm) air space. Each panel secured in position with aluminum pressure plates in conjunction with glazing gaskets and steel screws or with silicone structural glazing.
 - b. **Aluminum Panels** - Min 1/8 in. (3 mm) thick aluminum panels with nom 1/4 in. (6 mm) thick edges. Each panel secured in position with aluminum pressure plates in conjunction with gaskets and steel screws.
 - c. **Stone Panels** - Nom 1-3/16 in. (30 mm) thick polished granite spandrel panels with 1 in. (25 mm) thick gauged edges. Each panel secured in position with aluminum pressure plates in conjunction with gaskets and steel screws.
 - d. **Aluminum Composite Panels** - Min 1/8 in. (3 mm) thick aluminum composite comprised of min 0.2 in. (0.5 mm) aluminum skin with LDPE or mineral-filled Fire Resistant core. Each panel secured in position with steel furring channels in conjunction with gaskets and steel screws.
 - D. **Vision Panels** - Min 1/4 in. (6 mm) thick transparent heat-strengthened glass or min 1 in. (25 mm) thick insulated glass units with two layers of nom 1/4 in. (6 mm) thick transparent heat-strengthened glass separated by a min 1/2 in. (25 mm) air space. Each panel secured in position with aluminum pressure plates in conjunction with glazing gaskets and steel screws or with silicone structural glazing.

Design covered under US Patent No. 7,856,775 B2



Specified Technologies Inc. 210 Evans Way Somerville, NJ 08876

Reproduced courtesy of Underwriters Laboratories, Inc.

Created or Revised: October 12, 2016

(800)992-1180 • (908)526-8000 • FAX (908)231-8415 • E-Mail:techserv@stifirestop.com • Website:www.stifirestop.com



CW-S-0002
PAGE 1 OF 2

- E. **Steel Backpan** - No. 22 gauge (min 0.031 in. or 0.79 mm thick) galv steel panels installed between mullions and transoms within spandrel panel area. Steel backpan provided with min 1/2 in. (13 mm) wide lip around all four sides. Steel backpan installed flush with interior face of framing and screw-attached to mullions and transom along all sides with min No. 8 by 1/2 in. (13 mm) long self-drilling, self-tapping steel screws spaced max 8 in. (203 mm) OC.
- F. **Stiffener Tee** - Nom 1-1/2 in. deep by 3in. wide T-shaped stiffener formed of No. 22 gauge (min 0.031 in. or 0.79 mm thick) galv steel welded to exterior surface of steel backpan. Stiffener tee installed with its stem at an elevation 2 in. (51 mm) below the top surface of the floor such that, upon installation of the safing insulation (Item 3A), the stiffener channel will be located at the middepth of the safing insulation. The spot or stitch welds securing the stiffener tee to the backpan shall be spaced max 8 in. (203 mm) OC along the length of the tee with welds alternating between the top and bottom of the tee.
- G. **Curtain Wall Insulation*** - Min 2 in. (51 mm) thick mineral wool batt insulation faced on one side with aluminum foil/scrim vapor retarder. Insulation batts to be installed as a continuous piece with no seams, partially kerfed on one face to receive stem of stiffener tee. Insulation panels tightly-fitted between vertical mullions and the transoms and secured to steel backpan with No. 12 gauge steel weld pins with steel clinch shields or with cup head weld pins (Item 3D) spaced max 12 in. (305 mm) OC.

ROCKWOOL MALAYSIA SDN BHD - CURTAINROCK 80

ROXUL INC - CURTAINROCK 80

THERMAFIBER INC - FIRESpan 90

INDUSTRIAL INSULATION GROUP L L C - Type CW-8

- H. **Aluminum Sandwich Panel** - (Optional) - Min 1/8 in. (3 mm) solid aluminum panel or aluminum composite panel installed on exterior surface of curtain wall insulation (Item 2G).

3. **Safing System** - The safing system shall incorporate the following construction features:

- A. **Forming Material*** - Nom 4 pcf (64 kg/m³) density mineral wool batt insulation. Batt sections cut to a width equal to the thickness of the floor and stacked to a thickness which is min 50 percent greater than the width of the linear gap between the curtain wall insulation and the edge of the concrete floor slab. The forming material is compressed min 33 percent and inserted cut-edge-first into the linear gap such that it is flush with the top and bottom surfaces of the floor assembly. Adjoining lengths of forming material to be tightly butted with butted seams spaced min 24 in. (610 mm) OC. Forming material to be continuous beneath mullion mounting brackets (Item 2A).

ROCKWOOL MALAYSIA SDN BHD - Safe

ROXUL INC - Safe

THERMAFIBER INC - SAF

INDUSTRIAL INSULATION GROUP L L C - MinWool-1200 Safing

- B. **Fill, Void or Cavity Material*** - Min 1/8 in. (3 mm) wet thickness (1/16 in. or 1.5 mm dry thickness) of fill material spray-applied over top of forming material and lapping min 1/2 in. (13 mm) onto the top surface of the floor and onto the steel backpan. When SpecSeal Fast Tack Spray is used, wet and dry thickness of spray is min 5/64 in. (2 mm).

SPECIFIED TECHNOLOGIES INC - SpecSeal AS200 Elastomeric Spray or SpecSeal Fast Tack Spray

- C. **Safing Shelf - Curtain Wall Insulation*** - Nom 2 in. (51 mm) thick mineral wool batt insulation faced on one side with aluminum foil/scrim vapor retarder. Min 8 in. (203 mm) wide strips butted tightly against bottom of safing insulation (Item 3A), continuous over the steel backpans and mullions, and secured to the steel backpan with cup head weld pins (Item 3D) spaced max 12 in. (305 mm) OC.

ROCKWOOL MALAYSIA SDN BHD - CURTAINROCK 80

ROXUL INC - CURTAINROCK 80

THERMAFIBER INC - FIRESpan 90

INDUSTRIAL INSULATION GROUP L L C - Type CW-8

- D. **Weld Pin** - Nom 2 in. (51 mm) long No. 12 gauge galv steel weld pin with nom 1-3/16 in. (30 mm) diam galv steel cup head used to secure curtain wall insulation (Item 3C) to steel backpan.

* Indicates such products shall bear the UL or cUL Certification Mark for jurisdictions employing the UL or cUL Certification (such as Canada), respectively.

Design covered under US Patent No. 7,856,775 B2



Specified Technologies Inc. 210 Evans Way Somerville, NJ 08876

Reproduced courtesy of Underwriters Laboratories, Inc.

Created or Revised: October 12, 2016

(800)992-1180 • (908)526-8000 • FAX (908)231-8415 • E-Mail:techserv@stifirestop.com • Website:www.stifirestop.com



CW-S-0002
PAGE 2 OF 2