

## System No. CW-D-2004

F Rating - 3 Hr

T Rating - 1/4 Hr

Integrity Rating - 3Hr

Insulation Rating - 1/4 Hr

Linear Opening Width - 8 In. Max

L Rating At Ambient - Less Than 1 CFM/Lin Ft

L Rating At 400°F - Less Than 1 CFM/Lin Ft

Class II Movement Capabilities - 5% Vertical Shear (See Item 3)

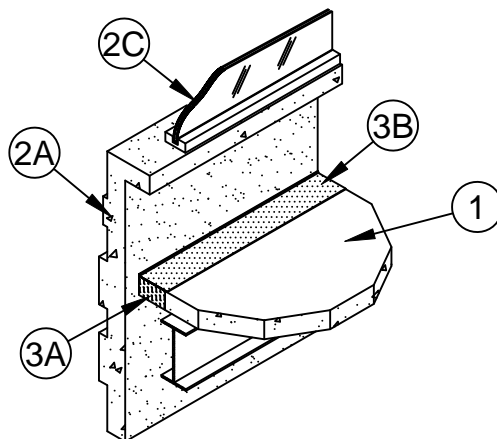

1. **Floor Assembly** - Min 4-1/2 in. (114 mm) thick steel-reinforced lightweight or normal weight (100-150 pcf or 1600-2400 kg/m<sup>3</sup>) structural concrete. Floor assembly to be supported at perimeter edges by spandrel beams having a Restrained or Unrestrained Beam Rating of 3 hr.
2. **Curtain Wall Assembly** - The curtain wall assembly shall incorporate the following construction features:
  - A. **Spandrel Panels** - Min 36 in. (914 mm) high by min 4 in. (102 mm) thick steel-reinforced lightweight or normal weight (100-150 pcf or 1600-2400 kg/m<sup>3</sup>) concrete spandrel panels. Wall may also consist of min 4 in. (102 mm) thick steel-reinforced lightweight or normal weight concrete tilt-up panels with a min 36 in. (914 mm) vertical separation between window openings. Panels provided with steel dead load anchors welded to steel reinforcing bars embedded in the concrete for attachment to the steel columns and spandrel beams. Panels also provided with steel lateral anchors or braces. The dead load anchors which are located in the linear gap between the concrete floor slab and the spandrel panel or tilt-up panel are to be spaced max 72 in. (1829 mm) OC. The top of the dead load anchor is to be recessed min 1/2 in. (13 mm) from top surface of floor.
  - B. **Joint System** - (Not Shown) - Vertical joints between spandrel panels or tilt-up panels to be protected using Joint System No. WW-S-0038 or WW-S-0049.
  - C. **Framed Window** - Metal framed window with nom 1/4 in. (6 mm) thick heat-strengthened glass. Sill of window to be min 6 in. (152 mm) above top of floor.
3. **Safing System** - Max separation between edge of floor assembly and concrete spandrel or tilt-up panel is 8 in (203 mm). The safing system is designed to accommodate vertical shear movement between dead load anchors up to a max of 5 percent of its installed width. The safing system shall incorporate the following construction features:
  - A. **Forming Material\*** - Nom 4 in. (102 mm) thick mineral wool batt safing material to be installed between the concrete spandrel or tilt-up panel and the edge of the concrete floor slab. Safing material to be cut to a min 4 in. (102 mm) width and stacked to a thickness which is at least 25 percent greater than the width of the linear gap between the concrete spandrel or tilt-up panel and the edge of the concrete floor slab. The safing material is compressed and inserted cut-edge-first into the linear gap such that its top surface is flush with the top surface of the floor assembly. A max of one tightly-butted seam is permitted between dead load anchors. An additional min 1/2 in. (13 mm) thick piece of mineral wool batt safing material to be installed to cover top surface of each dead load anchor.

**ROCKWOOL MALAYSIA SDN BHD** - SAFE

**ROXUL INC** - SAFE

- B. **Fill, Void or Cavity Material\*** - Min 1/8 in. (3.2 mm) wet thickness of fill material spray-applied over top of forming material and lapping min 1/2 in. (13 mm) onto the top surface of the concrete floor and onto the concrete spandrel panel or tilt-up panel. When SpecSeal Fast Tack Spray is used, wet and dry thickness of spray is min 5/64 in. (2 mm).

**SPECIFIED TECHNOLOGIES INC** - SpecSeal AS200 Elastomeric Spray or SpecSeal Fast Tack Spray

\* Indicates such products shall bear the UL or cUL Certification Mark for jurisdictions employing the UL or cUL Certification (such as Canada), respectively.



**Specified Technologies Inc. 210 Evans Way Somerville, NJ 08876**

Reproduced courtesy of Underwriters Laboratories, Inc.

Created or Revised: January 18, 2017

(800)992-1180 • (908)526-8000 • FAX (908)231-8415 • E-Mail:techserv@stifirestop.com • Website:www.stifirestop.com



CW-D-2004  
PAGE 1 OF 1